



t h e

75



Z T

o w n e r s c l u b



Washer Reservoir - Removal

All models

Remove

- Remove the front wheel arch liner (drivers side)
- Remove 4 screws securing trim to bottom right-hand side of bumper and remove trim
- Disconnect the multiplug(s) from reservoir

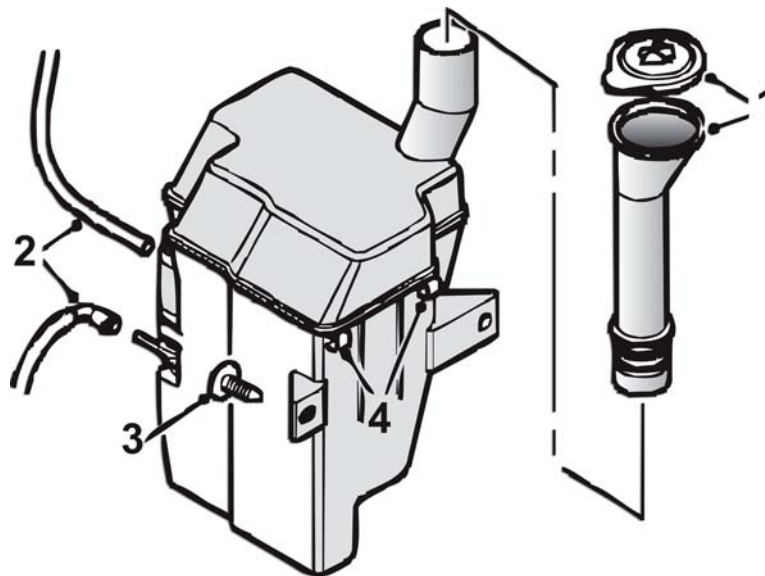

- Remove the filler cap and tube from the reservoir (1)
- Release the hose(s) from the reservoir and plug hole(s) (2)
- Remove the 2 scrivers securing the reservoir to the body (3)
- Release the 2 clips securing the reservoir to the body and remove the reservoir (4)

Refit:

- Fit the reservoir to the body and secure it with clips and scrivers.
- Fit the hose(s) to the reservoir.
- Connect the multiplug(s) to the reservoir.
- Fit the filler cap and tube to the reservoir.
- Fit the trim to the right-hand side of bumper and secure with screws.
- Fit the front wheel arch liner.

DISCLAIMER: This document is intended as a guide only. You assume all responsibility for any problems you may have as a result of reading these instructions. The 75 and ZT Owners Club and the author of this document shall not be held responsible for any losses or injury caused by the use of this document.